

SAFETY GATE CLOSING BLOCK - BLACK - SET OF 2 BOPLAN FLEX IMPACT SPECIFICATION

Revision: 6 June 2017 9:52 AM
Boplan reference: SG1010/0104

PRODUCT SPECIFICATIONS	
SIZE	
Outer dimension	56 mm x 70 mm x 8 mm
Fixations	6 Bolts BZK M6x25
Weight (Full Set)	74g
MATERIAL	
Closing Block	Polyolefin - UV resistant
Bolts	Galvanised Steel
COLORS	
Closing Block	Black
Bolts	Black
USAGE	
Environment	Indoor use only
Working Temperatures	-20°C up to +40°C

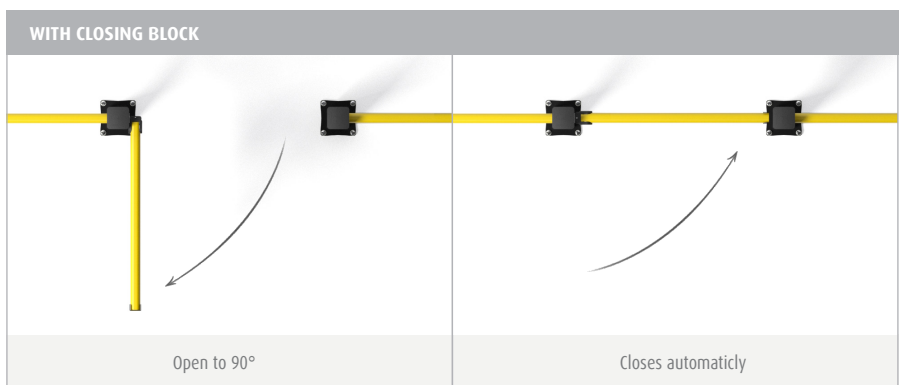
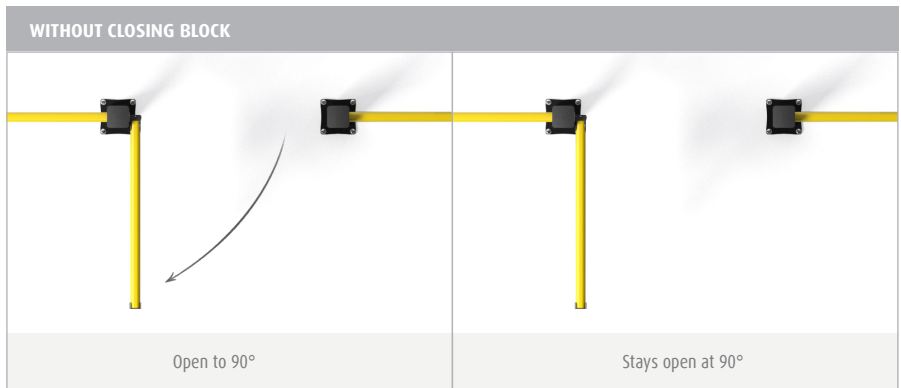
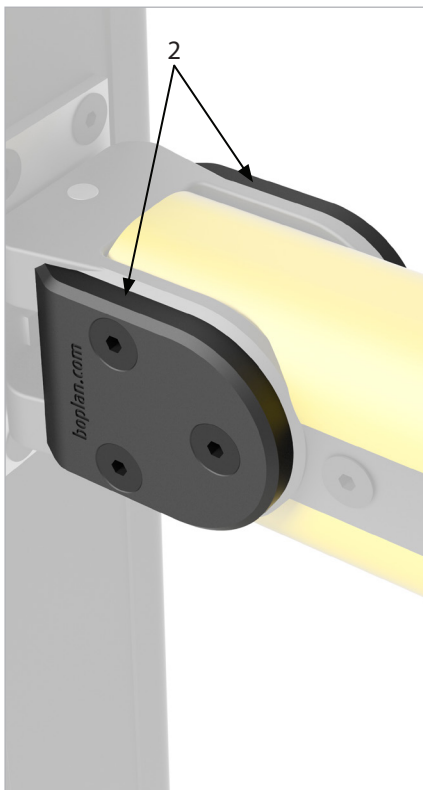

FEATURES AND FUNCTIONALITY

APPLICATION	
Automatic closing	The Closing block prevents the SG Swing gate from remaining open when opened 90° or more.
Advantages	Can be retro-fit to an existing Swing Gate. Impervious to most chemical products.
Maintenance	Clean dust with damp cloth. Clean grease stains with household detergent.

REQUIREMENTS	
Boplan Safety Gate	Compatible with SG Swing Gate only.
APPENDIX	
Technical Drawing	Available
Installation Sheet	Available

