

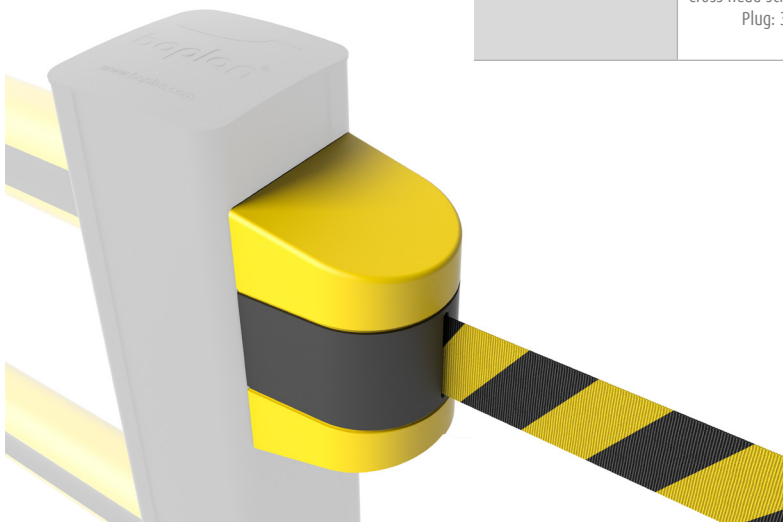

BELT BARRIER BOPLAN FLEX IMPACT SPECIFICATION SHEET

Boplan reference: BB - ...
Revision: 28 April 2021 11:33 AM



PRODUCT SPECIFICATIONS

APPLICATION

Environment	Quickly open and close restricted areas with the help of a belt barrier. Indoor use only.
Features	Automatic retracting mechanism Available in two lengths Highly visible because of the yellow / black strips on the webbing Easy to mount between walls, on a Boplan plastic post or between metal racks All fixations included, also magnets to mount to a metal structure
Operational temperature	-20°C up to +40°C
Attach to	A wall, rack beam, or other structure. 5 meter version: possible to attach to HP plus post (NOT to a HD light post). 10 meter version: not possible to attach to HP plus or HD light post.

MATERIAL

Housing	ABS
Webbing	Nylon
Internal components	Steel and plastic (spring in stainless steel)

STANDARD COLORS

Housing	Black body with yellow caps
Belt	Hazard (HZ) = Yellow / black stripes

SIZE AND PROPERTIES

	Belt Barrier - 5m (± 0,2)	Belt Barrier - 10m (± 0,2)
Outer dimensions	145(H) x 95 (W) x 90 (D)	167 (H) x 117 (W) x 109 (D)
Weight	490 gram	990 gram

FIXATIONS (included)

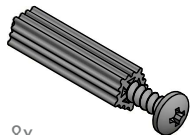
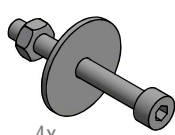
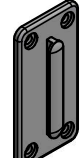
Type	 8X Cross head screw ZC: 30mm x Ø4mm Plug: 30mm x Ø9mm	 4X Nut M4 - ZC Bolt M4x25mm - ZC Washer - ZC	 1X Wall clip 40mm x 80mm
------	---	--	---

REFERENCE LIST - BELT BARRIER

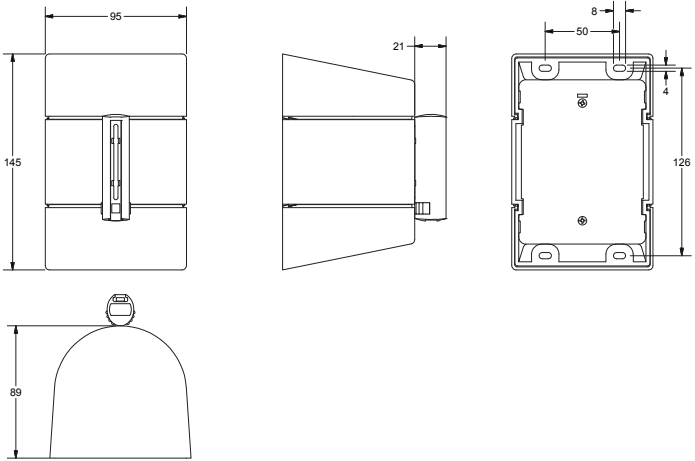
<p>BB0050-0050-HZ</p>	<p>Belt Barrier - 5M Color Belt: Hazard</p>	
<p>BB0100-0050-HZ</p>	<p>Belt Barrier - 10M Color Belt: Hazard</p>	